

STEREO INTEGRATED AMPLIFIER

KA-95



INSTRUCTION MANUAL

KENWOOD

TRIO-KENWOOD CORPORATION

©PRINTED IN JAPAN B50-6195-001K, U, UE(XT)
87/6 5 4 3 2 1 86/12 11 10 9 8 7 6 5 4

Rear panel safety precautions

<p>CAUTION</p> <p>RISK OF ELECTRIC SHOCK DO NOT OPEN</p>	<p>CAUTION. TO REDUCE THE RISK OF ELECTRIC SHOCK, DO NOT REMOVE COVER (OR BACK). NO USER-SERVICEABLE PARTS INSIDE. REFER SERVICING TO QUALIFIED SERVICE PERSONNEL.</p>
	<p>The lightning flash with arrowhead symbol, within an equilateral triangle, is intended to alert the user to the presence of uninsulated "dangerous voltage" within the product's enclosure; that may be of sufficient magnitude to constitute a risk of electric shock to persons</p>
	<p>The exclamation point within an equilateral triangle is intended to alert the user to the presence of important operating and maintenance (servicing) instructions in the literature accompanying the appliance.</p>

For your records

Record the serial number, found on the back of the unit, in the spaces designated on the warranty card, and in the space provided below. Refer to the model and serial numbers whenever you call upon your dealer for information or service on this product.

Model _____ Serial Number _____

Unpacking

Unpack the unit carefully and make sure that all accessories are put aside so they will not be lost.

Examine the unit for any possibility of shipping damage. If your unit is damaged or fails to operate, notify your dealer immediately. If your unit was shipped to you directly, notify the shipping company without delay. Only the consignee (the person or company receiving the unit) can file a claim against the carrier for shipping damage.

We recommend that you retain the original carton and packing materials for use should you transport or ship the unit in the future.

Important!

U.S.A., Canada, U.K. and Europe

Units shipped to the U.S.A. and Canada are designed for operation on 120 volts AC only. Units shipped to European countries are designed for operation on 220 volts AC only. Units shipped to the U.K. are designed for operation on 240 volts AC only. These units are not equipped with an AC voltage selector switch and the discussion of such a switch that follows should be disregarded.

All other countries

Units shipped to countries other than the U.S.A., Canada, U.K. and Europe are equipped with an AC voltage selector switch on the rear panel. Refer to the following paragraph for the proper setting of this switch.

Before applying power

AC voltage selection

This unit operates on 110 – 220 or 220 – 240 volts AC. The AC voltage selector switch on the rear panel is set to the voltage that prevails in the area to which the unit is shipped. Before connecting the power cord to your AC outlet, make sure that the setting position of this switch matches your line voltage. If not, it must be set to your voltage in accordance with the following direction.

Note:

Our warranty does not cover damage caused by excessive line voltage due to improper setting of the AC voltage selector switch.

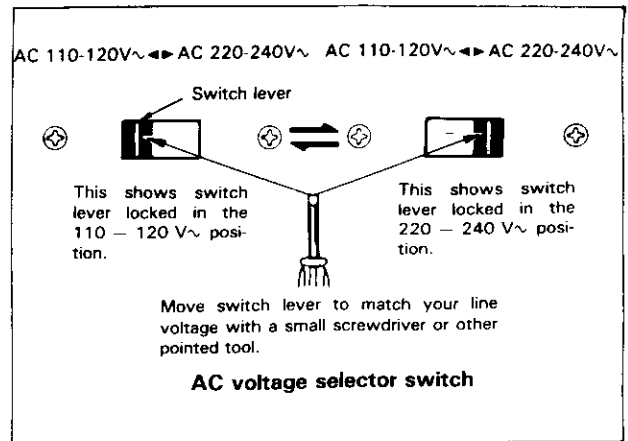

For United Kingdom

The mains plug must be removed from the wall socket prior to any internal examination.

Important

The wires in this mains lead are coloured in accordance with the following code:

Blue Neutral
Brown Live

The wires in this mains lead must be connected to the terminals in the plug as follows:

Wire colour Plug terminal marking

Blue N or Black
Brown L or Red

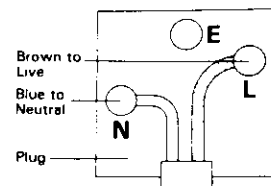

Notes:

- 1) If a 13-amp plug is used, this must be fitted with a 5-amp fuse.
- 2) If a 3-pin plug with earthing contact is used, no wire must be connected to the E terminal.

WARNING:

TO PREVENT FIRE OR ELECTRIC SHOCK, DO NOT EXPOSE THIS APPLIANCE TO RAIN OR MOISTURE.

Before operation

Notes on installation

Do not place the unit in a place which is exposed to direct sunlight, near a heating appliance, etc.

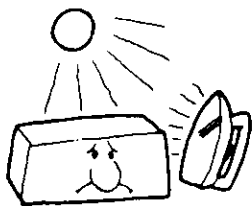

Do not place a vase containing water, makeup, etc. on the unit. Do not use in a humid place.

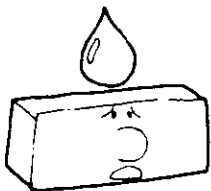

To maintain good ventilation, do not put records or a tablecloth on the unit. Place the unit at least 10 cm away from the walls.



Choose a location that is relatively free from vibration or excessive dust.

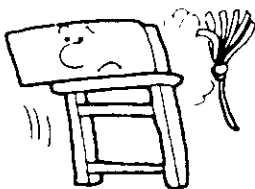

The unit may not function properly if used at extremely low, or freezing temperatures.



Safety precautions

Never remove the case. If the internal parts are touched, accidentally, a serious electric shock might occur.



Never touch internal parts.

If a metal object, such as a hair pin or a needle, comes into contact with the power socket on the rear panel, a dangerous electric shock may result. For families with children, never permit children to put anything, especially metal, inside this unit.



Touching the power plug when your hands are wet may result in a serious electric shock.

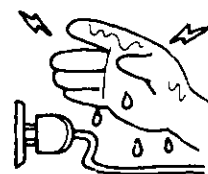

Never touch with wet hands.

Never pull, bend or extend the power cord. This could damage the power cord, resulting in a broken cord or short-circuit.

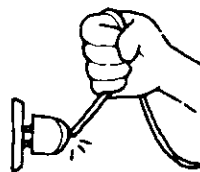

Always grasp the plug.

In case of abnormal smell

If an abnormal smell or smoke is detected, immediately turn the power OFF and pull out the power cord. Contact your dealer or nearest Service Station.

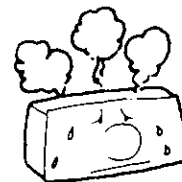

Cleaning

Do not use volatile solvents such as alcohol, paint thinner, gasoline, benzene, etc. to clean the cabinet. Use a silicone cloth or a clean dry cloth.

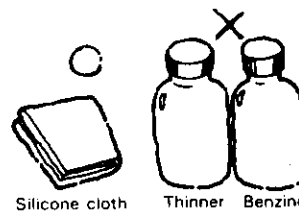

Silicone cloth

Thinner

Benzene

System connections

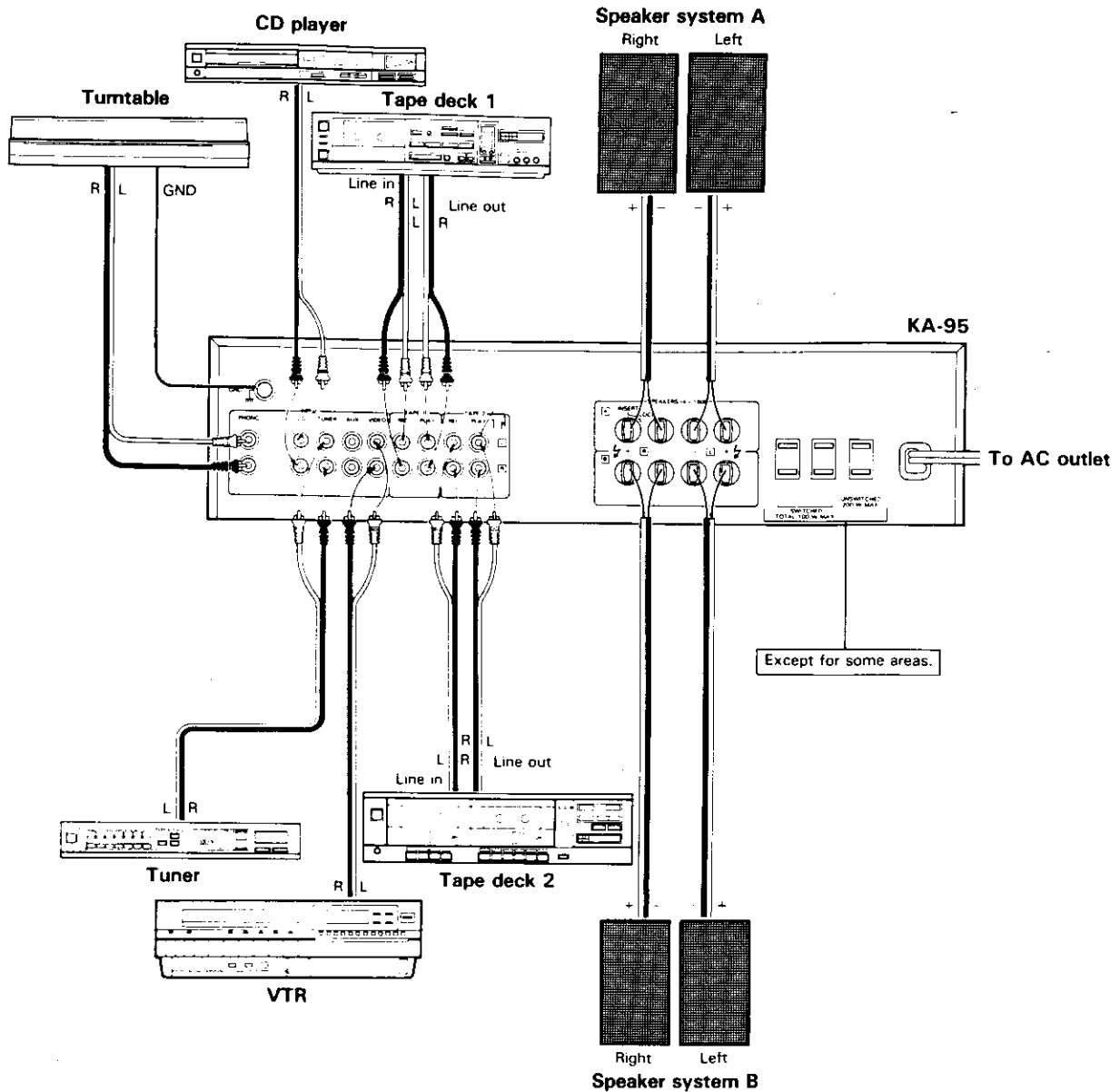

Speakers

This amplifier has two pairs of speaker terminals, SPEAKERS A and SPEAKERS B.

Connecting one speaker system

Connect speakers rated at 4 ohms or more to the SPEAKERS A terminals.

Connecting two speaker systems

To connect an additional pair of speakers, use the B terminals. In this case, each speaker must be rated at 4 ohms or more.

Connection with speaker cords

1. Connect the left speaker to the SPEAKERS terminals and the right speaker to the SPEAKERS terminals.

2. Be careful that wires do not contact adjacent terminals.

3. Be sure to connect the (+) terminal of the speaker to the (+) terminal of the amplifier.

Never short the (+) and (-) terminals.

Erroneous connection of speakers may result in poor imaging or unnatural sound.

① Remove insulation from lead tip. ② Twist wire tightly, and solder.

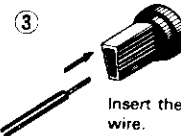

Speaker lead connection

Turntable

The PHONO jacks of the amplifier can accept a turntable with an MM type phono-cartridge.

Your stereo turntable has RCA pin-plug cords that is terminated with phono plugs. Plug the left channel plug into the **L** and the right channel plug into the **R** PHONO jacks.

If the turntable has a ground wire, connect it to the unit's GND terminal to avoid hum.

Tuner

Use the TUNER jacks for connection to an FM stereo or AM-FM stereo tuner.

Connect the left channel of the tuner to the **L** TUNER input jack and the right channel of the tuner to the **R** TUNER input jack.

CD

Use the CD jacks for connection to a CD player.

Connect the left channel of the CD player to the **L** CD jack and the right channel of the CD player to the **R** CD jack.

VTR

Use the VIDEO jacks for connection to a VTR. Connect the left channel of the VTR to the **L** VIDEO jack and the right channel of the VTR to the **R** VIDEO jack.

(Never connect these jacks to the video outputs of the VTR.)

AUX

To these jacks, high-level signal sources such as extra tape decks, TV, VTR sound outputs, etc. can be connected.

Ground

For maximum safety and minimum interference connect the GND terminal to a good earth ground if practicable. A good earth ground is a cold water pipe or a metal stake driven into moist earth. However, never use a gas pipe for this purpose.

Tape decks

If only one tape deck is to be connected to the system it is recommended that it be connected to the jacks marked TAPE 1.

Tape deck input and output cables are normally terminated with phono plugs.

Playback

Plug the left and right output cables of the tape deck into the **L** and **R** TAPE 1 PLAY jacks.

Record

Plug the left and right input cables of the tape deck into the **L** and **R** TAPE 1 REC jacks.

Second tape deck

Plug the input and output cables from the second tape deck into the REC and PLAY jacks marked TAPE 2.

AC outlets (Except some countries)

The AC outlets on the rear panel of the power supply unit may be used to supply power to other components in the system, such as turntables, tape decks, etc. Never connect equipment whose power consumption exceeds the maximum value shown at each outlet.

- 1. SWITCHED outlets:** These outlets supply power only when the unit is turned on. The maximum total capacity (both outlets) is 100 watts.
- 2. UNSWITCHED outlet:** The outlet provides power when the unit is plugged into an active AC wall outlet, regardless of the setting of the POWER switch. The maximum capacity is 200 watts.

Controls and indicators

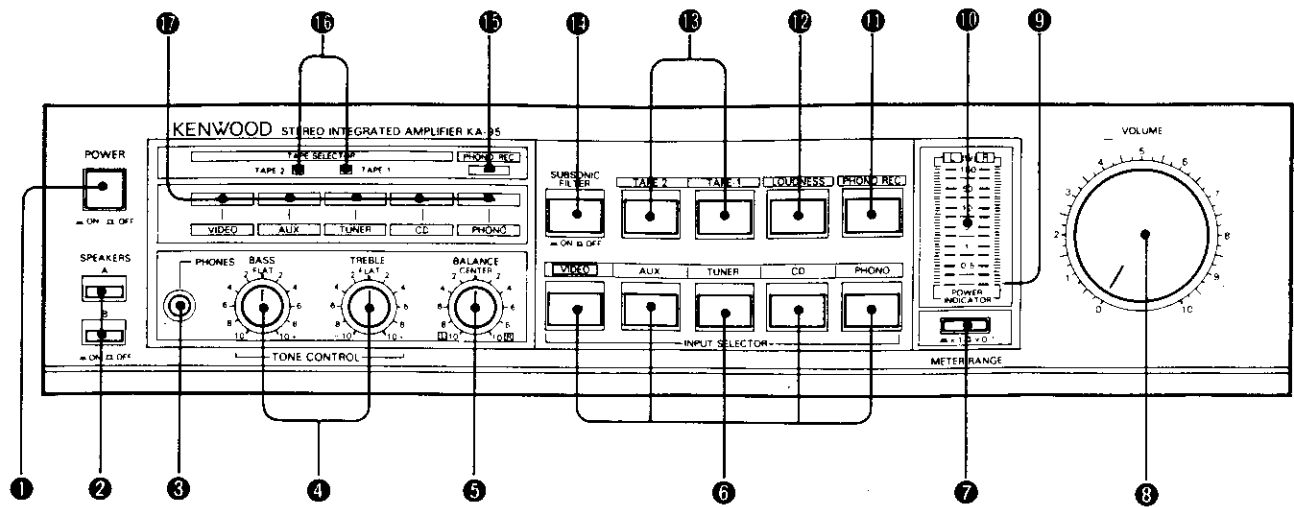

1 POWER switch

Press this switch to turn on the power. Press it again to turn the power off.

2 SPEAKERS switch

A, B OFF – This position silences all speakers to permit private use of headphones.

A ON – Activates speakers connected to the SPEAKERS A terminals on the rear panel.

B ON – Activates speakers connected to the SPEAKERS B terminals on the rear panel.

A, B ON – Activates speakers connected to the SPEAKERS A and B terminals simultaneously.

3 PHONES jack

Stereo headphones are plugged into this jack.

4 TONE CONTROLS

BASS – Turn from the FLAT position to the right to increase bass response.

Turn to the left to lower bass response.

TREBLE – Turn from the FLAT position to the right to increase treble response.

Turn to the left to lower treble response.

5 BALANCE control

This control permits balancing of left and right channels when an imbalance exists from the sound source, or to correct acoustic imbalance due to room conditions. Turn it to the left from the CENTER position to boost the left channel, turn it to the right of the CENTER position to raise the level of the right channel.

6 INPUT SELECTOR switches

PHONO – Selects the program source played on the turntable.

TUNER – Selects the tuner connected to the TUNER jacks.

VIDEO – Selects the VTR connected to the VIDEO jacks.

CD – Selects the CD player connected to the CD jacks.

AUX – Selects the source connected to the AUX jacks.

7 METER RANGE button

× 0.1 – Use this setting for normal operation.

× 1 – Use this setting when the VOLUME control is adjusted for a very high volume level.

8 VOLUME control

This control adjusts left- and right-channel volume simultaneously. Set it for the desired listening level.

9 POWER INDICATOR

Lights when the power switch (POWER) is set to ON.

10 POWER meters

These meters show the power being delivered to your speakers.

11 PHONO REC switch

When this switch is set to the in position, PHONO REC indicator lights up and the sound from the connected turntable can be applied to the TAPE 1 REC jacks regardless of the INPUT SELECTOR setting. When an INPUT SELECTOR switch is pressed and this switch is set to the in position, disc sound can be recorded on the tape deck connected to the TAPE 1 REC jacks while listening to a program source selected by the INPUT SELECTOR switch. For normal operation, set the switch to the out position (the indicator is off).

Note:

The selected source is output at TAPE 2 jacks.

12 LOUDNESS switch

ON – Bass notes are boosted at low listening levels. This precisely offsets a characteristic of human hearing whereby we are less sensitive to bass notes at very low listening levels.

OFF – The low-level bass boost is removed and the VOLUME control provides flat response at all settings.

13 TAPE-1 and TAPE-2 switches

TAPE-1 – Press this switch to play back a tape deck connected to TAPE 1 jacks.

TAPE-2 – Press this switch to play back a tape deck connected to TAPE 2 jacks.

Note:

When both switches are pressed, TAPE-1 setting has priority.

14 SUBSONIC FILTER switch

OFF – With this setting, frequency response is perfectly linear.

ON – In this setting signals below 18 Hz are attenuated at the rate of 6 dB per octave. Although such signals are inaudible, they can cause intermodulation distortion components in the audible range.

15 PHONO REC indicator

16 TAPE SELECTOR indicators

TAPE-1 – Lights when the TAPE-1 switch is pressed.

TAPE-2 – Lights when the TAPE-2 switch is pressed.

17 Input indicators

The indicator lights corresponding to the INPUT SELECTOR switch pressed.

Operating instructions

Volume, tone, balance and loudness

1. Adjust bass and treble to suit your taste.
2. If an imbalance occurs (the left or right channel appears louder than the other) due to source imbalance or room acoustics, adjust the BALANCE control to equalize the sound from both speakers.
3. If you customarily listen at low listening levels, set the LOUDNESS switch to ON. If not, set it to the OFF position.

Playing a program source selected by an INPUT SELECTOR switch

1. Press the INPUT SELECTOR switch of the program source to be played.
2. Operate the system of the program and set it to play-back mode.
3. Adjust the volume and tone to your preference.

Tape decks

Tape playback

1. Press the appropriate TAPE switch (1 or 2) to select output from a tape deck connected to the TAPE 1 or 2 jacks.
2. Operate the tape deck.
3. Adjust volume and tone to your preference.

Note:

When both switches (TAPE-1 and TAPE-2) are pressed, TAPE-1 setting has priority.

Recording

1. Press the appropriate INPUT SELECTOR switches.
2. Set up your tape deck(s) for recording and set the recording level with the controls on your tape deck(s). The VOLUME and TONE CONTROLS on the amplifier do not affect the signal applied to the tape deck(s) for recording.
3. Adjust listening level and tone at the amplifier to suit your listening preference.

Tape Dubbing

Tape recordings may be duplicated (dubbed) easily using two tape decks connected to the TAPE 2 and 1 jacks. Tape dubbing is possible from the tape deck connected to the TAPE 2 jacks to deck connected to the TAPE 1 jacks.

1. Connect two tape decks to the TAPE 1 and TAPE 2 jacks.
2. Press the TAPE-2 switch.
3. Play back the recorded tape and adjust the recording levels before starting tape dubbing.

Note:

Adjust record levels on the deck that is making the copy using that deck's operating controls.

To record a disc on tape while listening to a program source other than a disc

1. Press an INPUT SELECTOR switch other than PHONO and play the selected program source.
2. Set the PHONO REC switch to the in position.
3. Set the tape deck connected to the TAPE 1 REC jacks to recording mode and play the disc.

When the sound cannot be heard even if the operation is correct, turn off the power switch and check if the speaker terminals are not short-circuited.

Safety precaution for AC plug (for U.S.A. and Canada only)

CAUTION:

TO PREVENT ELECTRIC SHOCK DO NOT USE THIS (POLARIZED) PLUG WITH AN EXTENSION CORD, RECEPTACLE OR OTHER OUTLET UNLESS THE BLADES CAN BE FULLY INSERTED TO PREVENT BLADE EXPOSURE.

In case of difficulty

If your unit should not perform as expected, consult the table below to see if the problem can be corrected before seeking help from your dealer or service representative.

Symptom	Cause	Remedy
No power, no sound.	1. Power cord not plugged in. 2. Poor connection at wall outlet. Power outlet inactive.	1. Check plug contact. 2. Check outlet using a lamp or other appliance (outlet may be controlled by a wall switch).
No sound from left and right.	1. Speaker cords disconnected. 2. Speakers switched off.	1. Check speaker connections. 2. Check speaker switch.
Sound from left or right, but not both.	1. Poor speaker connections. 2. Defective speaker.	1. Check connections at both ends of speaker cord. 2. Reverse speakers. If problem stays with speaker, have speaker checked.

Specifications

(IHF'66)

Power Amplifier Section

Rated Power Output

125 watts per channel minimum RMS, both channels driven at 8 ohms from 20 Hz to 20,000 Hz with no more than 0.05% total harmonic distortion

Both Channels Driven into 8 ohms at 1 kHz	125 W + 125 W (Except USA, Europe and U.K.)
Total Harmonic Distortion (AUX—SPKR 8 Ω)	
at Rated Output, 20 Hz ~ 20,000 Hz	0.05%
at 1/2 Rated Output, 20 Hz ~ 20,000 Hz	0.02%
at 1/2 Rated Output, 1 kHz	0.007%
(PHONO—SPKR 8 Ω : at -20 dB VOLUME Level)	
at Rated Output, 1 kHz	0.02%
Intermodulation Distortion (60 Hz:7 kHz = 4:1)	0.02% at rated power into 8 ohms
Damping Factor	20 (1,000 Hz into 8 ohms)
Frequency Response	10 Hz to 100 kHz, +0 dB, -3 dB
Input Sensitivity/Impedance	
Phono MM	2.5 mV/47 k ohms
TUNER, AUX., TAPE PLAY	150 mV/33 k ohms
Signal-to-Noise Ratio (IHF-A)	
Phono MM	73 dB for 2.5 mV input
Phono MM	79 dB for 5.0 mV input
TUNER, AUX., TAPE PLAY	100 dB
Maximum Input Level for Phono MM	140 mV (RMS), T.H.D. 0.05% at 1 kHz
Output Level/Impedance	
TAPE REC (Pin)	150 mV/3.3 k ohms
Frequency Response for Phono	RIAA standard curve ±0.3 dB (30 Hz to 20,000 Hz)
Tone Control	
Bass	±10 dB at 100 Hz
Treble	±8 dB at 10 kHz
Loudness Control (at -30 dB VOLUME Level)	+8 dB at 100 Hz
Subsonic Filter	18 Hz, 6 dB/oct.
General	
Power Consumption	4.1 A (USA and Canada : UL and CSA) 230 W (Others)
AC Outlets	Switched 2, Unswitched 1 (Except some countries)
Dimensions	W 420 mm (16-9/16") H 109 mm (4-5/16") D 280 mm (11")
Weight (Net)	8.5 kg (18.7 lb)

Note:

We are a party of continuous advancements in development. For this reason specifications may be changed without notice.